

W200x + W410x

up to NB 750 wall pipes and NB 600 medium pipes

► Type W200SS + W410SS

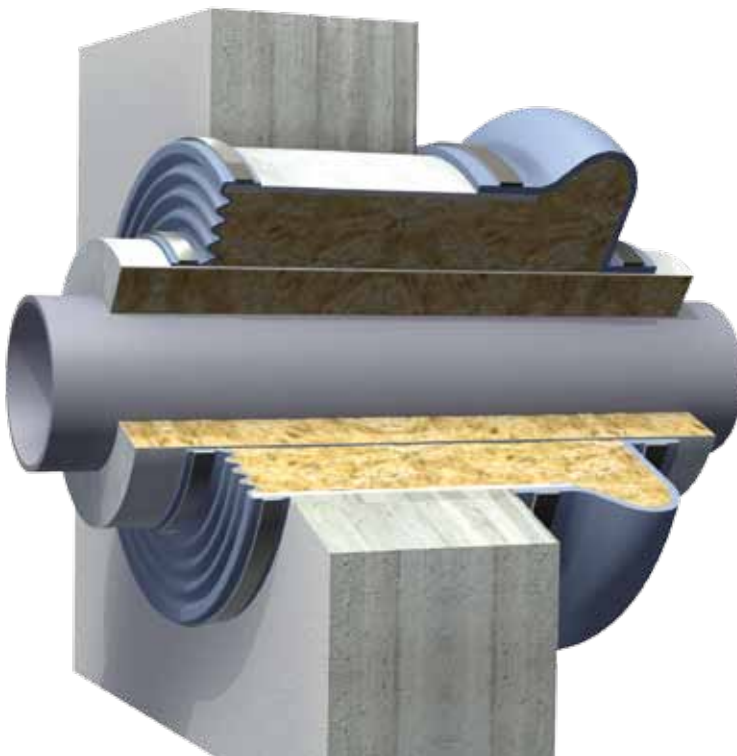

Type key ► page 20

W4 1 0 SS
 └─ Fixing variants
 └─ Support ring variants
 └─ Number of arches
 └─ Type

Application:

Power plants, plant construction,
turbine houses,
R90 fire protection bulkhead for
pipe penetrations with axial and
lateral movements

Tested according to DIN 4102, Section 11 General
Building Supervision Certificate MPA Braunschweig
No. P-3740/4280-MPA BS

R90 fire protection bulkhead for pipe penetrations up to wall pipe NB 750 and medium pipe NB 600 for large movements

Design:	Fire protection bulkhead possessing General Building Supervision Certificate consisting of elastic seals with clamped or flanged fixing on both sides of the wall or ceiling and a ring gap insulating layer	
Wall side:	A	B
Type:	Membrane type W200x Wall/ceiling sealing membrane with or without pre-shaped folds	Expansion joint type W410x Wall/ceiling sealing expansion joint with pre-formed arch
Fixing:	Onto the wall or medium pipe on both sides using sleeves for clamped fixing, type W200SS; Optional dowelled to the wall with clamping flange if there is no wall pipe (min. 30 x 6), type W200FS	Both sides to the wall and medium pipe using sleeves for clamped fixing, type W410SS For ceiling ducts: Expansion joint must be protected against slippage using a welding bead or round bar (approx. Ø 3 mm) at the end of the wall pipe overhang Optional dowelled to the wall pipe with a clamping flange (min. 40 x 6) dowelled to the wall, type W410FS
Installation length:	Standard 60 mm, other installation lengths on request	Standard 210 mm, other installation lengths on request
Options:	Membrane with installation seam for installation after the pipeline is laid Consideration of potential eccentricity between medium and wall pipe	Expansion joint with installation seam for installation after the pipeline is laid Consideration of potential eccentricity between medium and wall pipe

Wall pipe: Certification up to NB 750, intermediate sizes possible, use normal nominal bores if possible
Minimum required distance between individual wall pipes: 100 mm
Wall pipe thickness (► page 350–351)

- Wall pipe insulation:** For wall pipes thicker than 10 mm and a wall pipe overhang greater than 30 mm for membranes and 60 mm for expansion joints, the space not covered by the seal should be insulated using a 20 mm mineral wool insulation layer (materials class A1, melting point > 1000°C). The surface of this insulating material should be shielded using a galvanised or stainless steel plate with a thickness of 0.5 to 2.0 mm
- Medium pipe:** Certified up to NB 600, intermediate sizes possible
- Sectional medium pipe insulation:** Mineral wool insulation (materials class A1, melting point > 1000°C). The surface of this insulating material should be shielded using a galvanised or stainless steel belt with a thickness of 0.5 to 2.0 mm. Length and thickness (▶ page 346)
- Ring gap:** = Distance between wall pipe and medium pipe or sectional medium pipe insulation
Depending on Building Supervisory Certification, 10 mm to 100 mm required
Ring gap stuffing made from mineral wool (materials class A1, melting point > 1000°C)
Stuffing density $\geq 120 \text{ kg/m}^3$ (usually supplied by others)
For ceiling ducts: Insulation must be secured against slippage using several brackets around the circumference
- Pipe suspension:** Distance of pipe suspension to fire protection bulkhead max. 0.5 m
Distance between individual pipe suspensions max. 1.2 m
If a suspension penetrates the sectional medium pipe insulation, it must be furnished with insulation at least 30 mm thick and 300 mm high
- Wall/ceiling thickness:** min. 200 mm concrete, reinforced concrete or gas concrete
- Pressure:** Up to ± 20 mbar
- Movement:** For large axial and lateral movements (▶ page 350–351)

Elastic sealing

	Membrane W200SS and W200FS	Expansion joint W400SS and W410FS
Rubber grade:	up to 200 °C: Silicon (Q) for air, water, seawater atmospheres Special silicone blend for nuclear applications	
Carrier:	without	Silicate fabric

Fastening clamps

	Membrane W200SS and W200FS	Expansion joint W410SS and W410FS
Design:	Screw thread belt or small clamps	Endless clamp belt or hinge bolt clamp
Width:	Screw thread belt: $\frac{1}{2}$ " Small clamp: depending on \varnothing : 9–12 mm	Endless clamp belt: $\frac{3}{4}$ " Hinge bolt clamp: depending on \varnothing : 18–30 mm
Materials:	Screw thread belt with threaded screw lug: 1.4310 Small clamp, belt and housing: 1.4016 (Screw steel galvanised)	Endless clamp belt with screw lugs (tongs): 1.7300 Hinge bolt clamp, belt and housing: 1.4016 (Screw steel galvanised)

Flange

- Design:** Multi-part clamping flange with clearance holes
- Flange norms:** According to manufacturer specification
- Materials:** Carbon steel: 1.0038 (S235JRG2)
1.0570 (S355J2G3)
Stainless steel: 1.4301 (X5CrNi18-10)
1.4571 (X6CrNiMoTi17-12-2)
Other materials on request
- Coating:** Primed, hot-dip galvanised, special paint

Planning help W200SS + W200SS

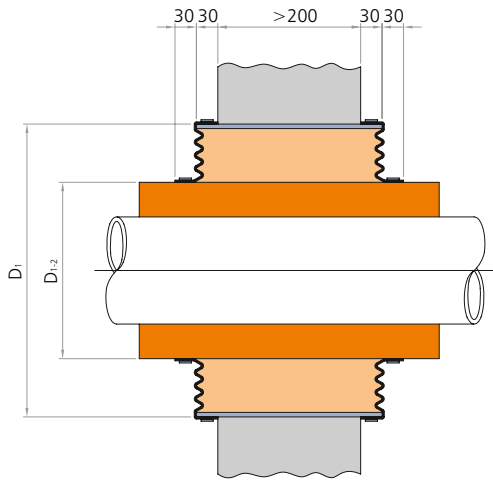

Planning help W200FS + W200FS

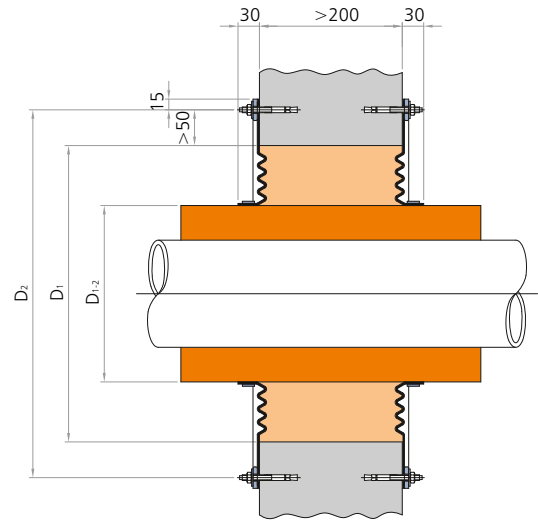

Planning help W200SS + W400SS

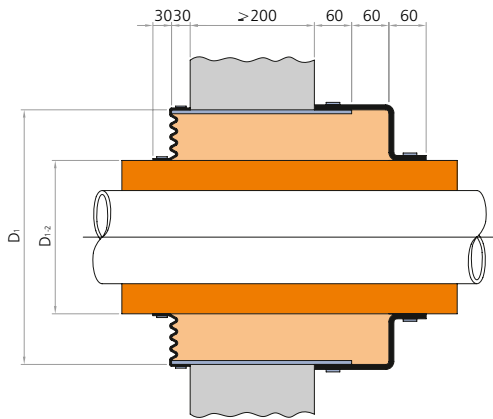

Planning help W200FS + W400FS

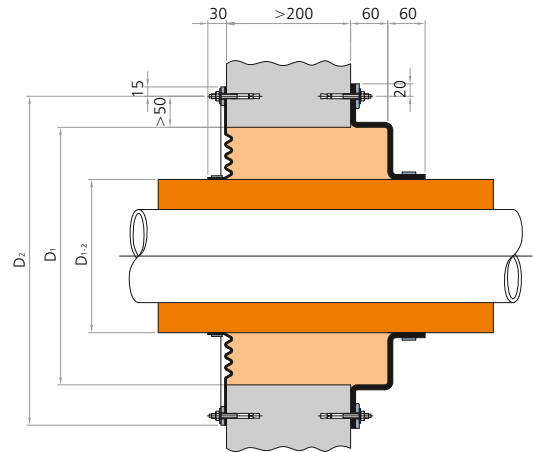

Planning help W200SS + W410SS

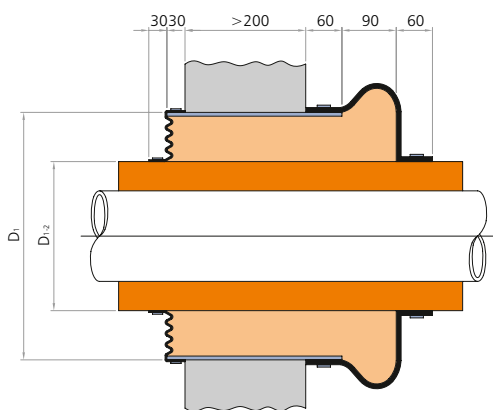

Planning help W200FS + W410FS

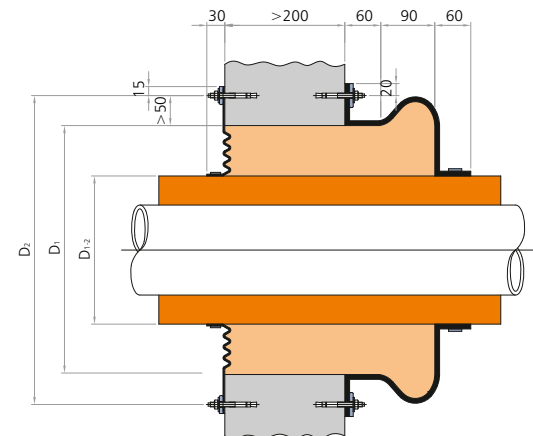



Membrane, type W200SS
to seal fire protection bulkhead



Expansion joint, type W410SS
to seal fire protection bulkhead