

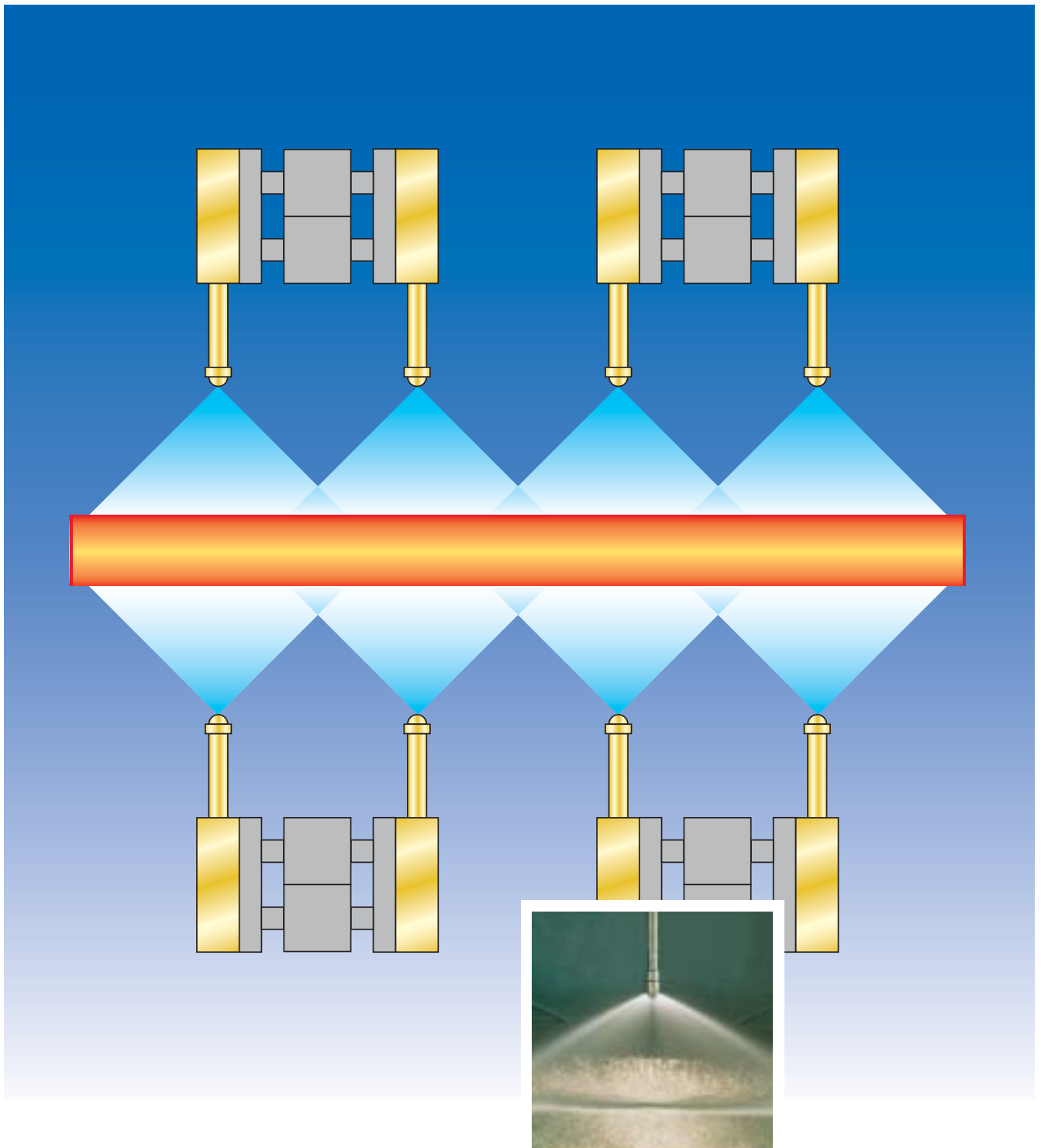

## MasterCooler SMART<sup>®</sup>

Air Mist Nozzle for Slab- and Beam Blank Casters



# MasterCooler SMART®

## The latest air mist technology and user benefits

### The problem

Because of their internal mixture, air mist nozzles require two separate feed pipes for compressed air and water. Until recently small diameter hydraulic pipes were used to feed the fluids from the headers and to hold the nozzles in place. The conventional air mist nozzles mounted on these small pipes are hidden inside the segment framework and are difficult to access.

Having the nozzles mounted so close to the strand makes maintenance (cleaning or adjustment) impossible unless the segment is removed from the machine. Moreover, in case of a break out nozzles must be replaced completely which is very costly.

Strand surface defects can often be traced back to misaligned spray nozzles. Small connection pipes between nozzles and headers are one source of such misalignments. The many small air and water pipes are often out of position due to mechanical impact or thermal reasons. The large number of small individually bent pipes are also expensive to manufacture.

Due to the nozzle mounting position on the segment rear side it is not unusual that the overall nozzle length becomes 1000mm and longer. A strand breakout could lead to an expensive replacement of a number of complete long nozzles.

### Beam Blank casters

Depending on the beam blank dimensions complicated header pipes, small specially bent fluid feed pipes and a fluid distributor have to be individually designed to accommodate standard air mist nozzles. Correct nozzle alignment, mounting and maintenance is difficult, time consuming and expensive.

### The solution

#### MasterCooler SMART®

The air mist nozzles are now equipped with a plate bolted vertically onto adaptor plates. Small diameter fluid feed pipes are no longer necessary. All nozzles are mounted outside of the framework at the rear side of the segment with only the nozzle pipe, carrying the spray tip, reaching down to the spray position. A very rigid header pipe and a nozzle self alignment is the result. The nozzle spray position is always secured. A "Hoseless" fluid supply system becomes also possible.

The mixture between compressed air and water takes place away from the hot zone inside the mixing chamber which is an internal part of the vertical plate. Hence, only one single nozzle pipe, exempt of any restrictions, supplies the premixed fluids to the nozzle tip.

Nozzle staggering between the roller gaps within one segment becomes much easier since different nozzle positions can be served from only one header pipe manifold. Nozzle staggering is one method to equalize the water distribution along the strand in length direction with the intention to eliminate surface defects and cracks.

#### MasterCooler SMART® Split Pipe design

For nozzles with extension pipes longer than appr. 300mm it is recommendable to install nozzles of the "Split Pipe" version allowing to separate the front part carrying the nozzle tip and nut only. The nozzle's vertical plate together with the remaining part of the pipe can be retained. The position of the joint between the two pipe ends can be designed as per request. A self aligning design identical to the one of the nozzle tip also secures the correct spray direction at this point. A cost saving feature interesting enough especially for top segments near the mould.

#### Beam Blank casters

The nozzles and header pipes with the vertical plate connection are also an ideal solution for beam blank casters. The advantages described above are also true here. The bends of the nozzle extension pipes can be made to suit. With the aid of the "Split pipe" design the two nozzles on either side can be identical with the front pipe turned by 180°.

# MasterCooler SMART®

## Typical nozzle arrangements and designs

### Slab Casters

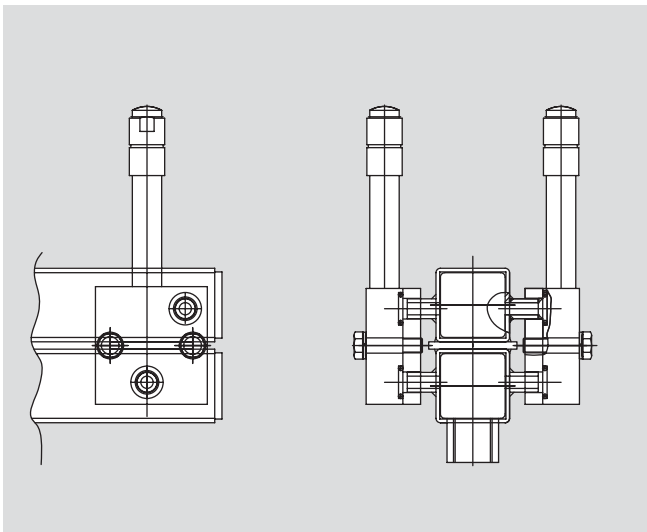

Header design with square air and water pipes for MasterCooler SMART®



Vertical headers for MasterCooler SMART® air mist nozzles  
(Source: Hüttenwerke Krupp Mannesmann (HKM) Germany, 2-strand slab caster)

### Split Pipe Design

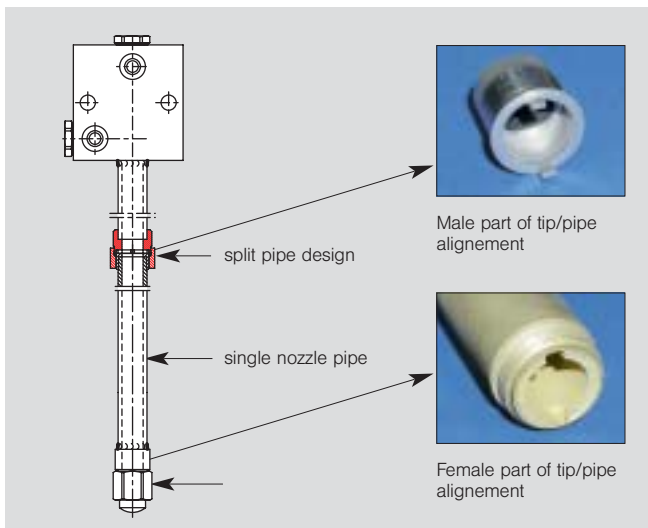

MasterCooler SMART® Split Pipe design with self aligning tip and pipe

### Beam Blank Casters

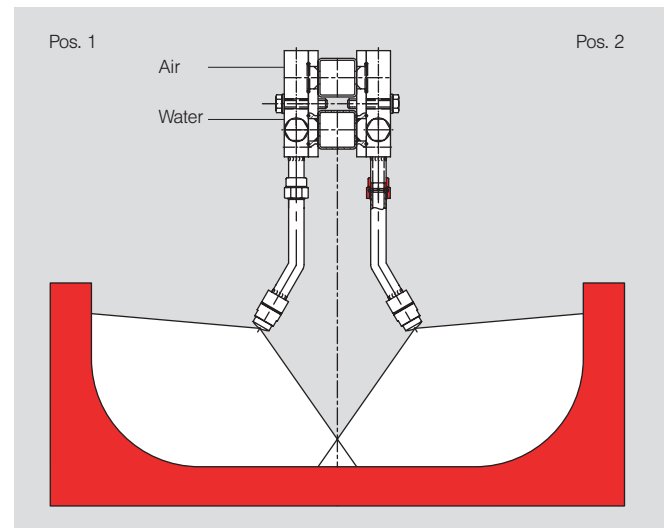

Header design with square air and water pipes for MasterCooler SMART® and Split Pipe design. Two nozzle positions with only one nozzle type. Split extension pipe offset by 180°.

# MasterCooler SMART®

## Technical data



Lechler GmbH  
 Precision Nozzles · Nozzle Systems  
 P.O. Box 13 23  
 72544 Metzingen / Germany  
 Phone +49 (0) 71 23 - 962 - 0  
 Fax +49 (0) 71 23 - 962 - 333

E-Mail: [info@lechler.de](mailto:info@lechler.de)  
 Internet: [www.lechler.de](http://www.lechler.de)

Standard size	Min. standard water flow at 0,5 bar water pressure	Min. standard water flow at 7 bar water pressure	Max. standard air flow at 0,5 bar water pressure
	All values at 2 bar constant air pressure		
	l/min	l/min	Nm <sup>3</sup> /hr
1,5	0,9	5,7	6,8
2	1,3	7,6	9,1
2,5	1,6	9,5	11,4
3	2,0	11,7	14,0
3,5	2,2	13,2	15,9
4	2,7	16,3	19,6
4,5	3,0	18,0	21,6
5	3,2	18,9	22,7
5,5	3,5	20,8	25,0
6	3,8	22,7	27,3
6,5	4,1	24,6	29,5
7	4,4	26,5	31,8
7,5	4,7	28,4	34,1
8	5,2	31,0	37,2
8,5	5,4	32,2	38,6
9	5,6	33,8	40,6
9,5	6,0	36,0	43,1
10	6,3	37,9	45,4
10,5	6,6	39,7	47,7
11	6,9	41,6	50,0
11,5	7,3	43,5	52,2
12	7,6	45,4	54,5
12,5	7,9	47,3	56,8
13	8,2	49,2	59,0
13,5	8,5	51,1	61,3

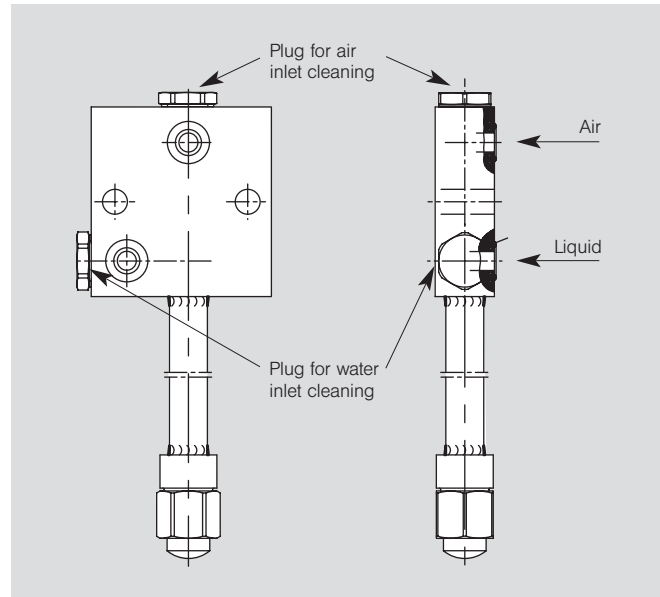

- Extension pipe length to suit
- Bent pipes possible (1 or 2 planes)
- Split pipe design on request
- Material: Body in brass, tip brass nickel plated or SS

Standard spray angles: degrees 50; 80; 90; 110; 120

### The special features

- Vertical plate connection
- Uniform water distribution over turn down ratio
- Stable spray angle over turn down ratio
- High heat transfer coefficient
- Water and air plugs for easy cleaning

### The benefits

- Very rigid and economical header design
- Uniform cooling over entire slab width
- Prevents transversal cracks and core segregation
- Easy maintenance



# HENNLICH GmbH & Co KG

*Düsenteknik*

A-4780-Schärding, Alfred-Kubin-Straße 9 a-c, Tel.: 07712/3163-0, Fax: 07712/3163-24, Email: [duesenteknik@hennlich.at](mailto:duesenteknik@hennlich.at), [www.hennlich.at](http://www.hennlich.at)