

# Changeover Valves

## Type 06401 - Changeover Valve DN25



### Cryogenic Changeover Valves, stainless steel, PN125

for the installation of two safety valves,  
with two test connections G 1/4,  
"cleaned and degreased for oxygen service"

#### Part No. 06401.0250.9045

In- and Outlet: locking sleeve G 1

#### Part No. 06401.0250.9\*\*\*

\*\*\* Changeover valves with other threads for  
vessel or safety valve connection on request

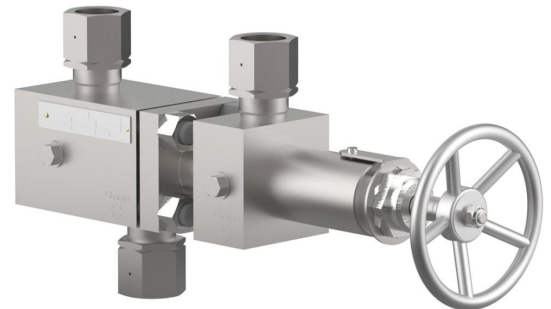

Available options - on request only:

- Changeover valves with pneumatic or electric actuator
- Inlet GW and/or outlet GA with female thread (G) acc. to ISO 228/1
- Inlet GW and/or outlet GA with female thread NPT acc. to ANSI B 1.20.1
- Combination of different thread connections GW - GA

### Applications:

Approved for air gases, vapours and cryogenic liquefied gases incl. LNG.  
Working temperature: -196°C / -321°F (77K) up to +185°C / +365°F (458K)

Materials	DIN EN	ASTM
1 Body	1.4571	A 276 Grade 316Ti
2 Plug	1.4571	A 276 Grade 316Ti
3 Disc stem	1.4571	A 276 Grade 316Ti
4 Valve seal	PCTFE	
5 Disc	1.4571	A 276 Grade 316Ti
6 Disc stem	1.4571	A 276 Grade 316Ti
7 Gland packing	PTFE / Carbon filled (25%)	
8 Head piece	CW452K nickel plated	B 159 UNS C51900 nickel plated
9 Stem	1.4571	A 276 Grade 316Ti
10 Handwheel	Aluminium alloy	
11 Welding piece	1.4571	A 276 Grade 316Ti
12 Locking sleeve	1.4571	A 276 Grade 316Ti
13 Thread connection	1.4571	A 276 Grade 316Ti

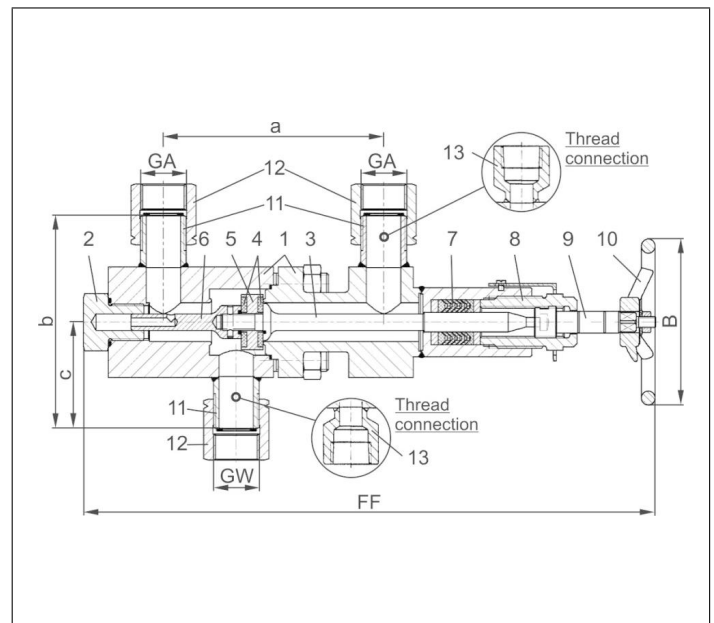

Typ 06401 - Standard design	Technical data	
Nominal size	DN	25
Inlet	GW	G 1
Outlet	GA	G 1
Face-to-face dimension	FF	415
Handwheel-Ø	B	120
Length	a	160
Height	b	160
Length	c	80
Weight	ca. kg	11.7
Kvs - Value, one side open	m <sup>3</sup> /h	13.0
Cv - Value, one side open	gal /min	15.0
Kvs - Value, central position	m <sup>3</sup> /h	15.5
Cv - Value, central position	gal /min	17.9

Dimensions in mm.